

# Cape Heated Towel Rack Installation Guide

2023.6

- These units should be installed by a certified electrician in accordance with the National Electrical Code (NEC) and the Canadian Electrical Code (CEC).
- The unit requires a 120 volt, 60Hz power source and should be installed on a GFCI protected circuit.
- Follow installation instructions to ensure unit is securely fixed to wall.
- Unit is designed for hanging, drying and warming towels or other articles of clothing. Under no circumstances should anybody climb on or hang on unit.
- Unit is intended for indoor use.
- Surface temperature can increase depending on the ambient temperature in the room and the number of towels applied to the unit.
- The fasteners provided with the installation kit are for convenience only and are not suitable for all installations.
- To ensure the Heated Towel Rail is mounted securely, fasteners should be secured in studs or structural members placed behind the rails.
- It is the ultimate responsibility of the installer to ensure proper mounting hardware is employed in attaching the unit to the wall.
- After installation, connect the electric power.
- Allow 15-30 minutes to heat up.
- This rack is designed and safe to run continuously with a simple on/off switch for control. However, it can also be wired to a timer for scheduled control.
- Towels which contain soap or detergent residue may appear to have scorch marks; this is simply discoloration of the residue. These discoloration marks will disappear after a couple of wash cycles.
- The unit is constructed from extremely durable 304 stainless steel. To maintain a good appearance, follow these simple instructions:
  1. For routine cleaning, simply switch off the unit, allow to cool to room temperature, wipe with a damp cloth and buff with a soft, dry cloth.
  2. Under no circumstances should abrasive cleaners be used to clean the unit.

## Included Components

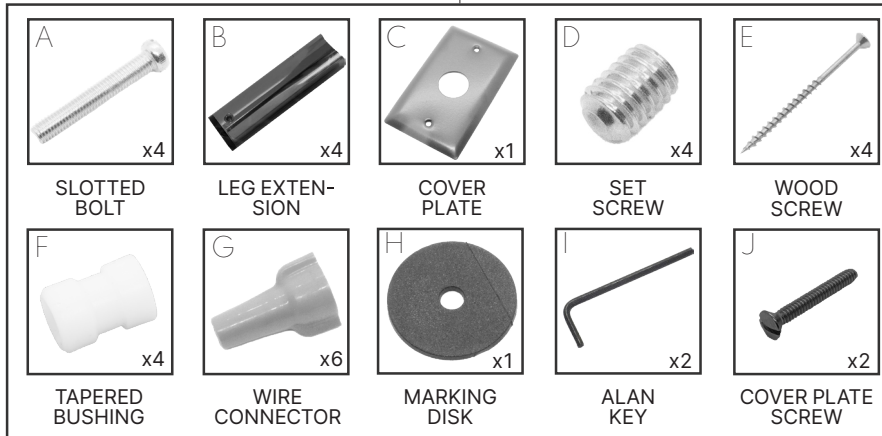

## Tools Required

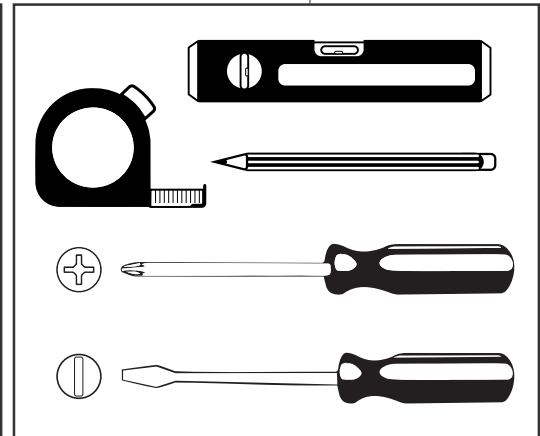

## Mounting Leg Assembly

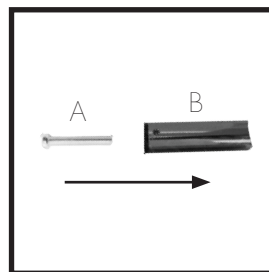
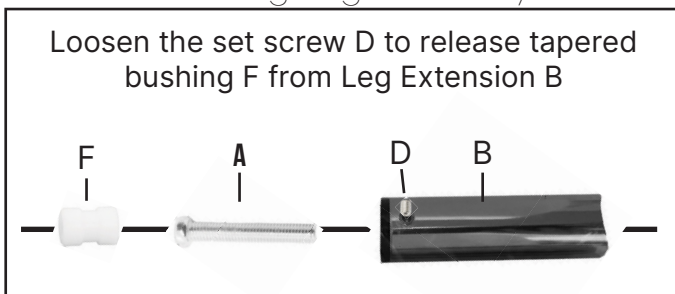

FIG 1

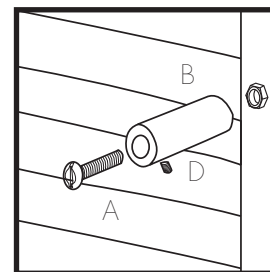

FIG 2

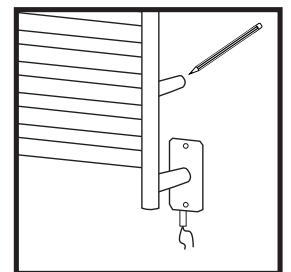

FIG 3

## Step 1

Insert the slotted bolt (part A) through the leg extension (part B), as shown in (fig. 1), for all 4 leg extensions. Fasten the bolt into the threaded nut welded onto the back of the unit, using a flat head screw driver, as shown in (fig. 2). \*Note - make sure the set screw (part D) on the leg extension is facing down, do not tighten yet. Decide where to install unit and the location of the single gang junction box. This can be done by either placing the assembled rack against the wall or taking approximate dimensions from the drawing supplied.

## Step 2

Loosen the set screw at the bottom of the short feeder pipe where the electrical cord exits the unit. Position the slotted pipe on the electrical cord over the feeder pipe with the cut-away section facing downwards. Position the rubber grommet into the slot to protect the electrical cord.

## Step 3

The heated towel rack can be installed hardwired or as a plug-in unit.

### a) Plug-in installation option:

Position the unit on the wall and make sure it is mounted squarely and levelled. Use a pencil to lightly mark the position of all four leg extensions on the wall (fig. 3).

### b) Hardwire installation option:

Install single gang junction box in the desired position. Secure supplied cover plate onto box. Place unit against wall with wire cover tube inserted in cover plate. To achieve this, the cord needs to be fed through the slot at the end of the tube. Make sure the unit is mounted squarely and levelled. Use a pencil to lightly mark the position of all four leg extensions on the wall (fig. 3).

## Step 4

Remove unit and centre the marking disk (part H) in the circles marked on the wall in Step 2. Mark the centre of the hole using a pencil. Repeat for all legs. Place the tapered bushing (part F) onto the centre of the circles marked in (fig. 4), insert supplied wood screw through centre of the tapered bushing and fasten to wall as in (Fig 5). If rack is installed on a tiled surface use a toggle bolt anchor. If mounting to drywall without wood backing, drywall anchors or toggle bolt anchors are also recommended.

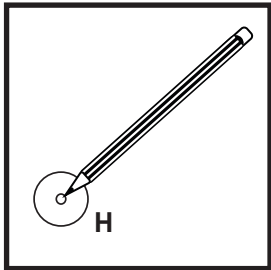

FIG 4

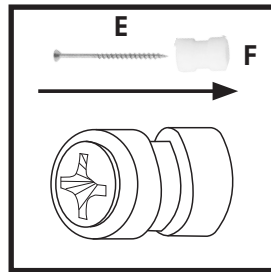

FIG 5

## Step 5

### a) Plug-in installation option:

Slide unit with leg extensions onto the 4 tapered bushings and using the supplied allen key (part I), tighten the set screw (part D) on all four legs to secure the unit to wall. The plug can now be plugged into the wall socket.

### b) Hardwire installation option:

Slide cover plate (part C) over tube with electrical wires (fig. 6) and make the electrical connections as outlined in the diagram below (fig. 8), using the provided wire connectors (part g). Slide unit with leg extensions onto the 4 tapered bushings and using the supplied allen key (part I), tighten the set screw (part D) on all four legs to secure the unit to wall. After properly securing all wire connections, push wires into box and secure cover plate to the junction box with provided cover plate screws (fig. 9). The towel rack can be connected to an optional timer.

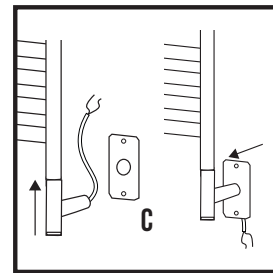

FIG 6

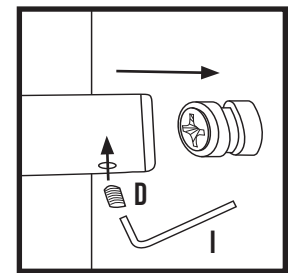

FIG 7

After being connected to an electrical supply, the heated towel rack can be switched on using the on/off switch located at the bottom of the right-hand vertical post.

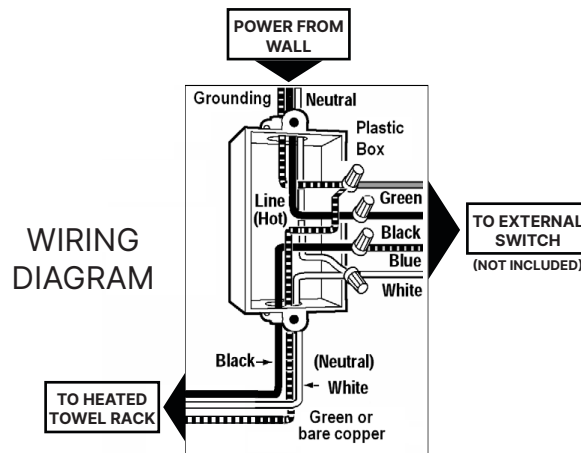

FIG 8

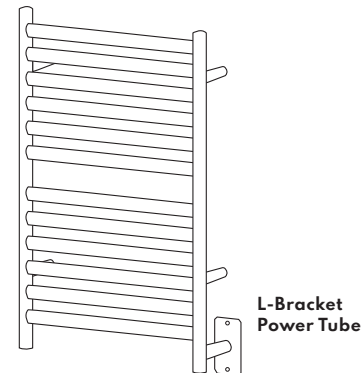

FIG 9